

Ceramic Patch Antenna APPLICATION

*** 本產品符合 RoHS 條款 ***

CUSTOMER: 環天世通科技股份有限公司

料號: N0AP1584252545



機種: BT-332

規格: Patch Antenna: 1584MHz

25x25x4mm, P/N: G250484PL50, SUPERRITE

CUSTOMER APPROVAL

秀波電子股份有限公司
Super Electronics Co., Ltd.

APPROVAL BY	CHECKED BY	DRAWING BY
		

Explanation of Part Number

G 25 04 84 P L50
(1) (2) (3) (4) (5) (6)

- (1) GPS
- (2) Dimension: length x width = 25x25 mm
- (3) Dimension: thickness = 4 mm
- (4) Center Frequency f_0 = 1584 MHz
- (5) Patch
- (6) PIN 5.0 mm

Super Electronics Co., Ltd.

環天世通科技承認書:測試報告彙總表(電子件-成分表)

材料來源調查:

環天品號: NOAP1584252545 機種名稱: BT-332

使用材料品名	使用材料編號	材料提供廠商	UL.No	備註: 目前 是否可回收
PATCH(裸片)	25X25 mm	秀波電子		
PIN	G312063	皓騰		
錫膏		歆倫		
銀膠	DNF7510SR	大州		
貼紙	G312052	斯貝克		

測試報告調查:

環天品號: NOAP1584252545 機種名稱: BT-332

使用材料品名	測試報告號碼	測試報告日期	測試方法	Pb	Cd	Hg	Cr6+	PBB	PBDE
PATCH(裸片)	CE/2012/B0046	2012. 11. 07	參考報告	N. D.	N. D.	N. D.	N. D.	N. D.	N. D.
PIN	CE/2012/B1945	2012. 11. 19	參考報告 (附件, 此為 RoHS 排除條款)	30500	N. D.	N. D.	N. D.		
錫膏	CANEC1214951401	2012. 11. 12	參考報告	51	N. D.	N. D.	N. D.	N. D.	N. D.
銀膠	F690101/LF-CTSAYAA13-01089	2013. 01. 16	參考報告	N. D.	N. D.	N. D.	N. D.	N. D.	N. D.
貼紙	CE/2012/C2745	2012. 12. 21	參考報告	N. D.	N. D.	N. D.	N. D.	N. D.	N. D.

*註 1: 測試數據填寫方式: 若數值為 N. D 請填 N. D/ 若 <就填寫 <多少=> 單位為: PPM

QR8204-14

Ceramic Patch Antenna

Application

Automotive, recreational, military, marine, aviation, surveying

Typical Electrical Properties

Characteristics	Specification	Unit	Conditions
Center Frequency f_0	1584.0 \pm 3.0	MHz	70X70mm 治具 不含背膠
Bandwidth	9.0 min	MHz	Return Loss \leq -10dB
Gain at Zenith	+5.0 typ.	dBi	@1584.0 MHz*
Gain at 10° elevation	-1 typ.	dBi	@1584.0 MHz*
Impedance	50	Ω	參考值
Frequency Temperature Coefficient	0 \pm 20	ppm/°C	-40°C to +85°C
Axial Ratio	3.0max	dB	@1584.0 MHz

※ Those spec are for super standard only.

Super Electronics Co., Ltd.

Product Dimension

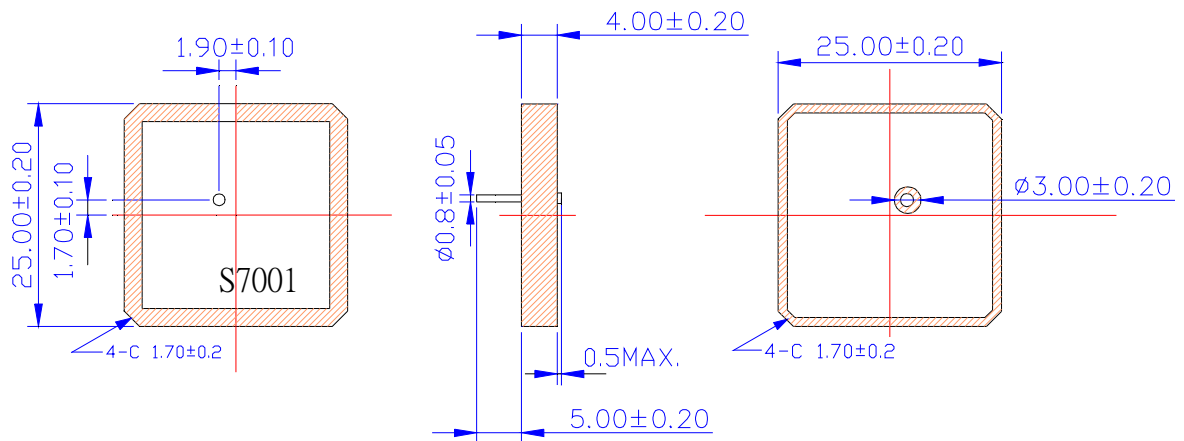

Unit : mm

Stick Type Position at Ceramic Patch Antenna

Thickness: 0.21

Release Liner: 0.13

Dimension: mm

Stick type: 3M-9472

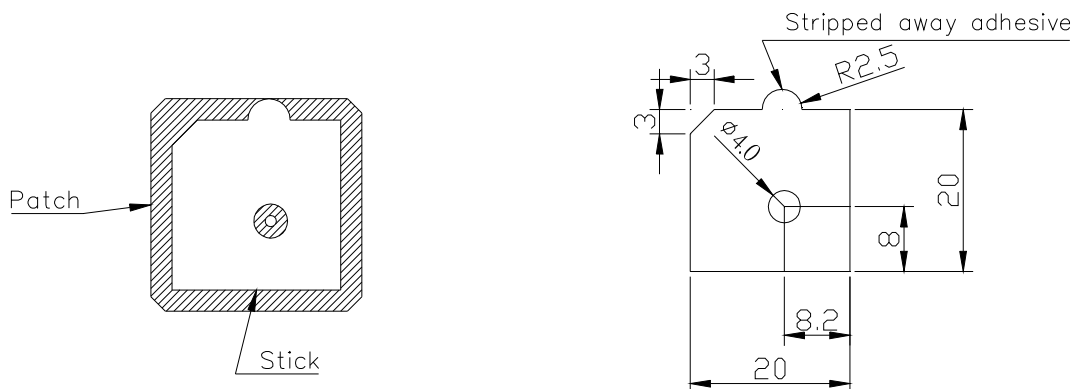

Tolerance: ± 0.5 mm

Super Electronics Co., Ltd.

Reflection Coefficient

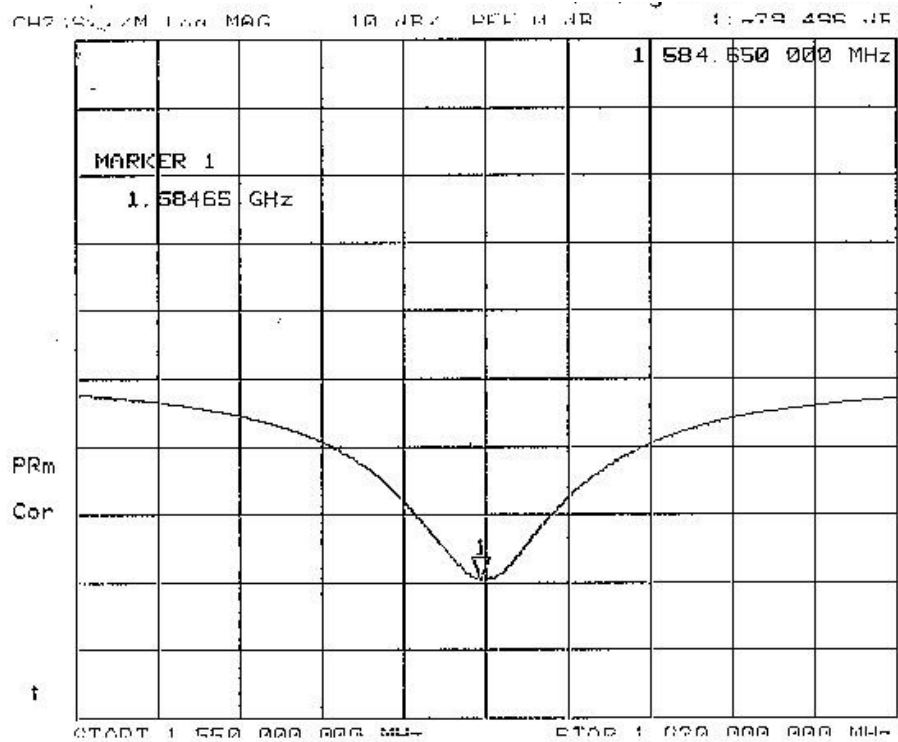

Input Impedance on a Smith Chart

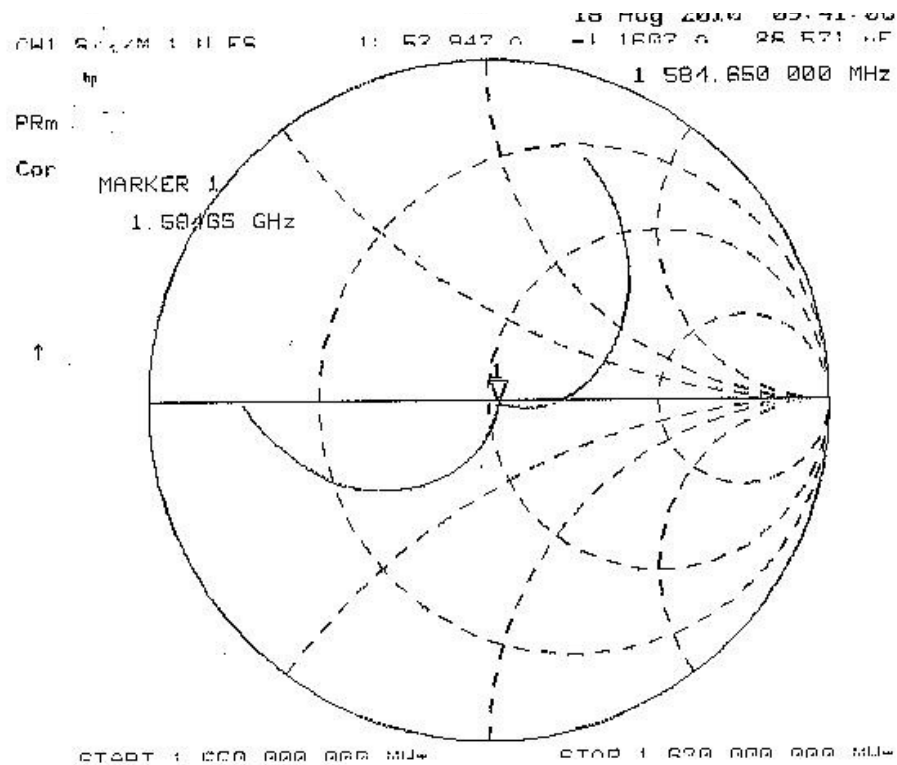

PACKAGE:

TRAY SIZE: 380× 205 × 18 (mm)

BOX SIZE: 400 ×228 × 194(mm)

A TRAY: 50 pcs

A BOX: 16 trays

A BOX: 800 pcs

NET WEIGHT: 9.0kg

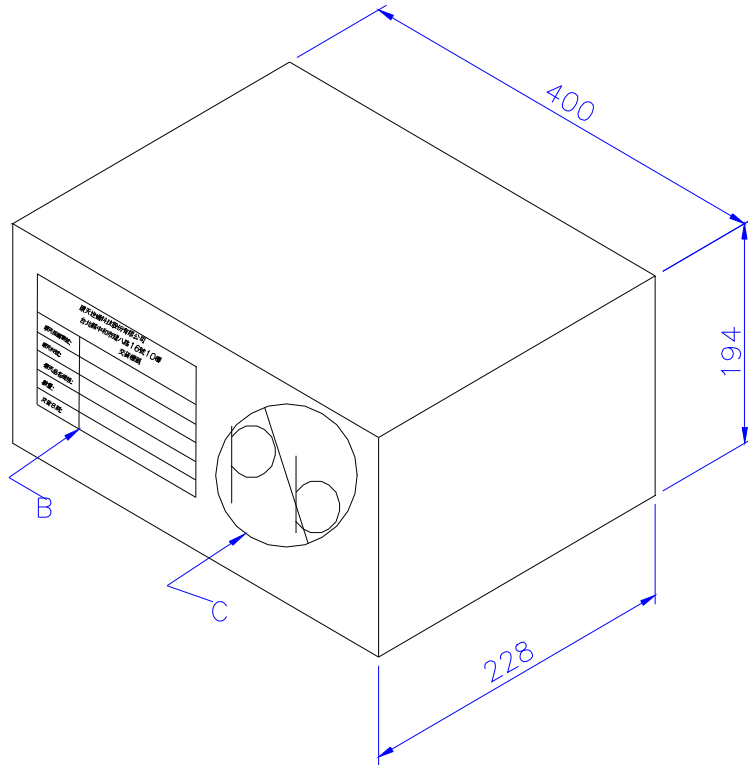

環天世通科技股份有限公司 台北縣中和市建八路16號10樓 交貨權籤	
環天採購單號:	
環天料號:	
環天品名規格:	
數量:	
交貨日期:	

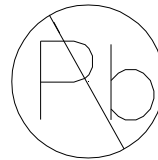

B

C

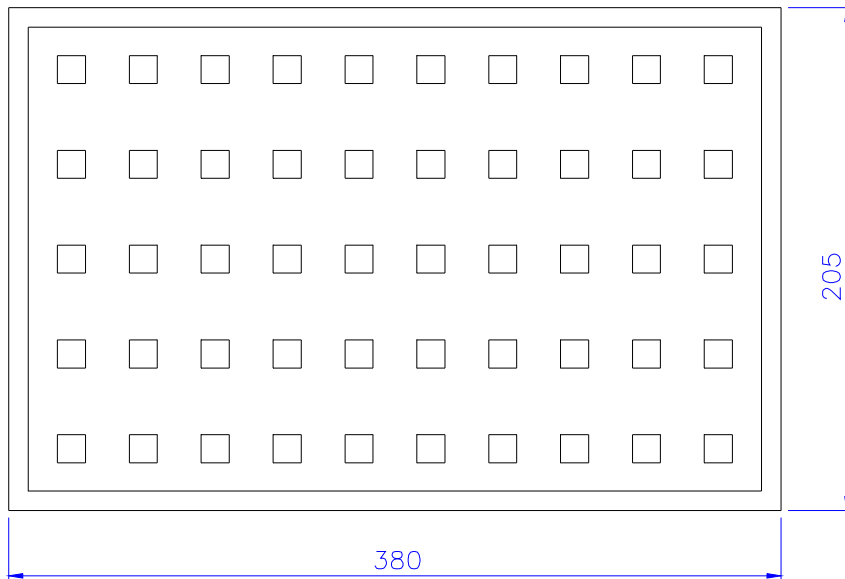

Super Electronics Co., Ltd.